

ENDÜSTRİYEL KAZAN SİSTEMLERİ
Industrial Boiler Systems



HİSARMAK

 www.hisarmak.com.tr





| | |
|-----------|--|
| 01 | Hakkımızda |
| 03 | Endüstriyel Kazan Sistemleri |
| 04 | Yakıtlarımız |
| 05 | Buhar Kazanı Ekipmanları |
| 06 | Sektörler |
| 07 | Skoç Tipi Buhar Kazanları |
| 09 | Döner Izgaralı Buhar ve Sıcak Su Kazanları |
| 11 | Akışkan Yataklı Buhar Kazanı |
| 12 | Akışkan Yataklı Kızgın Yağ Kazanı |
| 13 | Biyokütle ve Biomass Yakıtlı Buhar Kazanları |
| 15 | İleri İtimli Buhar Kazanı |
| 17 | Stokerli ve Otomatik Yükleme Buhar Kazanı |
| 19 | Skoç Tipi Sıcak Su Kazanları |
| 21 | Elektrikli Buhar Jeneratörleri |
| 23 | Kondens Tankları İmalatı |
| 24 | Degazör Tankları İmalatı |
| 25 | Torbalı Filtre |
| 27 | Ekonomizer İmalatı |
| 28 | Katı Yakıtlı Kazan Ekonomizeri |
| 29 | Islak Filtre |
| 30 | Multisiklon Filtre |
| 31 | Tandem Su Yumuşatma Sistemleri |
| 32 | Kum Filtre Sistemi |
| 33 | Hava Ekonomizer (Rekuperatör) İmalatı |
| 33 | Enerji Santralleri Çelik Kartuş İmalatı |
| 35 | Kazan Kontrol Ekipmanları |
| 36 | Kazan Yardımcı Ekipmanları |
| 38 | İmalatlarımız |
| 41 | Enerji Santralleri Kızdırıcı İmalatları |
| 43 | Referanslarımız |
| 45 | Buhar Tablosu |
| 47 | Sertifikalarımız |

| | |
|-----------|--|
| 01 | About Us |
| 03 | Industrial Boiler Systems |
| 04 | Fuel Types |
| 05 | Steam Boiler Equipment |
| 06 | Sectors |
| 07 | Scotch Type Steam Boilers |
| 09 | Rotary Grate Steam and Hot Water Boilers |
| 11 | Fluidized Bed Steam Boiler |
| 12 | Fluidized Bed Thermal Oil Boiler |
| 13 | Biomass Fueled Steam Boilers |
| 15 | Moving Grate Steam Boiler |
| 17 | Stoker & Automatic Fuel Loading Steam Boiler |
| 19 | Scotch Type Hot Water Boilers |
| 21 | Electric Steam Generators |
| 23 | Condensate Tanks Manufacturing |
| 24 | Deaerator Tanks Manufacturing |
| 25 | Bag Filter |
| 27 | Economizer Manufacturing |
| 28 | Solid Fuel Boiler Economizer |
| 29 | Wet Filter Scrubber |
| 30 | Multicyclone Filter |
| 31 | Tandem Water Softener Systems |
| 32 | Sand Filter |
| 33 | Air Economizer (Recuperator) Manufacturing |
| 33 | Power Plant Steel Cartridge Manufacturing |
| 35 | Boiler Control Equipment |
| 36 | Boiler Auxiliary Equipment |
| 38 | Our Manufacturing |
| 41 | Power Plant Superheater Manufacturing |
| 43 | Our References |
| 45 | Steam Table |
| 47 | Our certificates |



Hakkımızda

About Us



Temelleri enerji ve ısı sektörüne yönelik mühendislik çözümleri üretme vizyonuyla atılan Hisarmak, tekstil makineleri ve endüstriyel proses ekipmanlarındaki uzun yıllara dayanan deneyimini yeni bir alana taşıyarak 2015 yılında kurulmuştur. Kuruluşundan bu yana mühendislik gücünü, üretim kalitesini ve teknoloji yatırımlarını ön planda tutan firmamız, sektördeki hızlı yükselişiyle dikkat çekmektedir.

17.000 m² kapalı ve 6.000 m² açık alana sahip modern üretim tesisimizde, robot kaynak sistemleri, ileri düzey makine parkuru ve uzman mühendis kadromuz ile faaliyet göstermekteyiz. Mühendislikten üretime kadar tüm süreçler, kalite ve güvenliği esas alan bir yaklaşımla yürütülmektedir.

Hisarmak, endüstriyel kazanlar başta olmak üzere, enerji ve proses ekipmanları üretiminde yüksek verimlilik ve çevre dostu çözümler sunmayı amaçlamaktadır. Yurt içi projelerinin yanı sıra yurt dışında da tercih edilen bir marka olma yolunda emin adımlarla ilerleyen firmamız, ihracat hedeflerini genişleterek, Avrupa, Afrika ve Orta Doğu başta olmak üzere birçok ülkede faaliyetlerini artırmaktadır.

Üretim süreçlerimiz, uluslararası kalite standartlarına uygun olarak yürütülmekte olup, ürünlerimiz çeşitli akredite kuruluşlar tarafından belgelendirilmektedir. Bu doğrultuda, CE, ISO 9001, TSE gibi belgelerle üretim kalitemiz tescillenmiştir.

Ar-Ge faaliyetlerine büyük önem veren Hisarmak, enerji ve kazan teknolojilerinde yenilikçi çözümler sunmak adına mühendislik ekibiyle sürekli gelişim içerisinde. Yatırımlarını sürdüren firmamız, yüksek katma değerli ürünler ve özgün tasarımlarla sektörün geleceğine yön vermeye devam etmektedir.



Founded with the vision of providing engineering solutions for the energy and heat sector, Hisarmak was established in 2015 by leveraging its long-standing experience in textile machinery and industrial process equipment. Since its inception, our company has prioritized engineering expertise, production quality, and technological investment, and has garnered attention with its quick rise in the industry.

Operating from our modern production facility with 17,000 m² of indoor and 6,000 m² of open space, we utilize robotic welding systems, an advanced machinery park, and a team of expert engineers. All processes from engineering to production are carried out with a strong focus on quality and safety.

Hisarmak aims to provide high-efficiency and environmentally friendly solutions in the production of energy and process equipment, with a particular emphasis on industrial boilers. In addition to domestic projects, our company is steadily becoming a preferred brand internationally, expanding its export targets and increasing its presence in many countries, particularly in Europe, Africa, and the Middle East.

Our production processes comply with international quality standards, and our products are certified by various accredited organizations. In this context, our production quality has been certified with documents such as CE, ISO 9001, and TSE. Placing great importance on R&D activities, Hisarmak is in constant development with its engineering team to offer innovative solutions in energy and boiler technologies. Continuing its investments, our company aims to shape the future of the industry with high value-added products and original designs.



Skoç Tip Buhar Kazanı
Scotch Type Steam Boiler

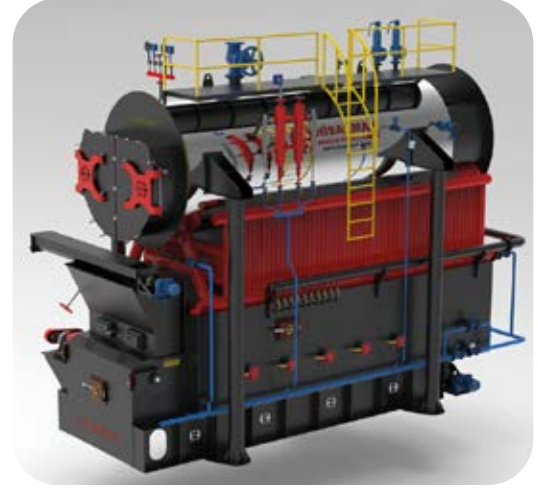

Döner Izgaralı Buhar Kazanı
Rotary Grate Steam Boiler



Akışkan Yataklı Buhar Kazanı
Fluidized Bed Steam Boiler



İleri İtimli Buhar Kazanı
Moving Grate Steam Boiler



Akışkan Yataklı Kızgın Yağ Kazanı
Fluidized Bed Hot Oil Boiler



Skoç Tipi Sıcak Su Kazanları
Scotch Type Hot Water Boilers



Linyit
Dust Coal



Odun Talaşı
Woodchips



Mısır Sapı
Corn Stalks



Pamuk Sapı
Cotton Stalks



Ayçiçek Kabuğu
Sunflower Reject



Pellet
Pellet



Pirina
Olive Pomace



Fındık Kabuğu
Nut Shells



Kağıt Rejecti
Pulper Reject



Pirinç Kavuzu
Rice Husk



Ağaç Kabuğu
Bark



Ağaç Kökü
Tree Roots

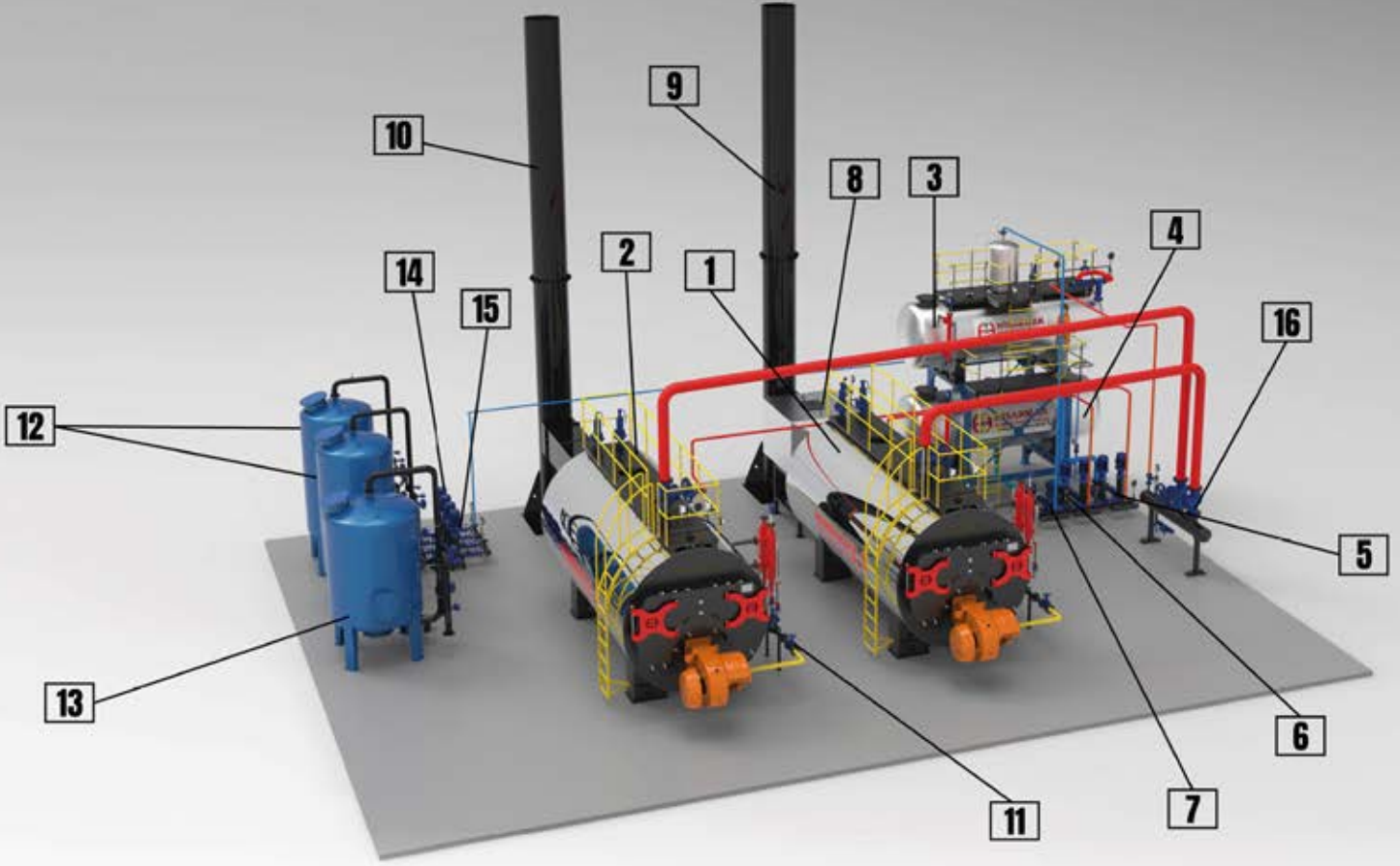

- | | |
|---|--|
| 1- Buhar Kazanı Skoç 1 Scotch Type Steam Boiler 1 | 9- Buhar Kazanı Baca 1 Steam Boiler Chimney 1 |
| 2- Buhar Kazanı Skoç 2 Scotch Type Steam Boiler 2 | 10- Buhar Kazanı Baca 2 Steam Boiler Chimney 2 |
| 3- Buhar Kazanı Degazör Tankı Steam Boiler Deaerator Tank | 11- Buhar Kazanı Gaz Dönüşüm İstasyonu Steam Boiler Gas Conversion Station |
| 4- Buhar Kazanı Kondens Tankı Steam Boiler Condensate Tank | 12- Buhar Kazanı Yumuşatma Tank Grubu Steam Boiler Softening Tank Group |
| 5- Buhar Kazanı Su Besleme Pompa Grubu 1 Steam Boiler Water Feed Pump Group 1 | 13- Buhar Kazanı Yumuşatma Kum Filtre Tankı Steam Boiler Softening Sand Filter Tank |
| 6- Buhar Kazanı Su Besleme Pompa Grubu 2 Steam Boiler Water Feed Pump Group 2 | 14- Buhar Kazanı Sert Su Hidrafor Grubu Steam Boiler Hard Water Hydrafor Group |
| 7- Buhar Kazanı Degazör Tankı Pompa Grubu Steam Boiler Deaerator Tank Pump Group | 15- Buhar Kazanı Yumuşak Su Hidrafor Grubu Steam Boiler Soft Water Hydrafor Group |
| 8- Buhar Kazanı Ekonomizer Steam Boiler Economizer | 16- Buhar Kazanı Kollektör Grubu Steam Boiler Collector Group |

Hizmet Sektörlerimiz

Tekstil

- Kumaş
- Boyama
- Denim
- Konfeksiyon

Gıda

- Meyve suyu
- Süt ürünleri
- Çikolata
- Makarna / Bulgur
- Salça / Yağ
- Tavuk / Yem

Kimya

- Boya üretimi
- Gübre üretimi
- Petrokimya tesisleri

Kağıt

- Kağıt hamuru üretimi
- Kraton üretimi
- Geri dönüşüm tesisleri

İnşaat

- Asfalt üretimi
- Yapı malzemeleri
- Endüstriyel tesisler

Çimento

- Gaz beton
- Prefabrik beton
- Klinker üretimi

Madencilik

- Altın zenginleştirme
- Kömür işleme tesisleri
- Maden cevheri kurutma

Demir / Çelik

- Dökümhaneler
- Galvaniz tesisleri
- Haddehaneler

Enerji

- Termik santraller
- Kojenerasyon tesisleri
- Biyokütle enerji santralleri

Sera

- Isıtma sistemleri

Cam / Seramik

- Fırın ve ısıtma sistemleri
- Sırlama hatları
- Kurutma hatları

Our Service Sectors

Textile

- Fabric
- Dyeing
- Denim
- Garment manufacturing

Food

- Fruit juice
- Dairy products
- Chocolate
- Pasta / Bulgur
- Tomato paste / Oil
- Chicken / Feed

Chemical

- Paint production
- Fertilizer production
- Petrochemical plants

Paper

- Pulp production
- Cardboard production
- Recycling plants

Construction

- Asphalt production
- Building materials
- Industrial facility

Cement

- Aerated concrete
- Precast concrete
- Clinker production

Mining

- Gold processing
- Coal processing
- Ore drying systems

Iron / Steel

- Foundries
- Galvanizing plants
- Rolling mills

Energy

- Thermal power plants
- Cogeneration plants
- Biomass power plants

Greenhouse

- Heating systems

Glass / Ceramics

- Kiln heating systems
- Glazing lines
- Drying lines



Sıvı & Gaz Yakıtlı Skoç Tipi Buhar Kazanları

Scotch Type Steam Boilers with Liquid & Gas Fuel



Özellikler

TR Skoç Tip Buhar Kazanları yüksek basınç gerektiren endüstriyel tesislerde en çok kullanılan sıvı ve gaz yakıtlı, alev-duman borulu, yüksek verimli ve tam silindirik buhar kazanlarıdır.

Büyük su hacmine sahip olmaları işletmelerin ani buhar ihtiyaçlarına hızlı cevap verebilmeyi sağlar.

Verimi %92 olup, ekonomizer ile bu oran %95'e çıkmaktadır.

Çalışma Prensipleri

Genellikle yatay silindirik tasarıma sahip olan bu kazan türünde iç kısımda yer alan borular aracılığı ile su, ısı kaynağı ile temas eder.

Yakıtın yanması sonucu ortaya çıkan sıcak gazlar, kazan içinde dolaşarak suyun buharlaşmasını sağlar.

Sertifikalar

Kazan, TS EN 12953 Standardına uygun olarak CE sertifikalı olacaktır.

Features

EN Scotch Type Steam Boilers are high-efficiency, fully cylindrical, fire-tube boilers that operate on liquid and gas fuels. They are the most commonly used steam boilers in industrial facilities requiring high pressure.

Their large water capacity allows them to quickly respond to the sudden steam demands of operations.

They have an efficiency of 92%, which can be increased to 95% when used with an economizer.

Working Principle

In these types of boilers that generally have a horizontal cylindrical design, water comes into contact with the heat source through the tubes located inside the boiler.

The hot gases produced from fuel combustion circulate inside the boiler, causing the water to vaporize.

Certificates

The boiler will be CE certified in accordance with the TS EN 12953 Standard.



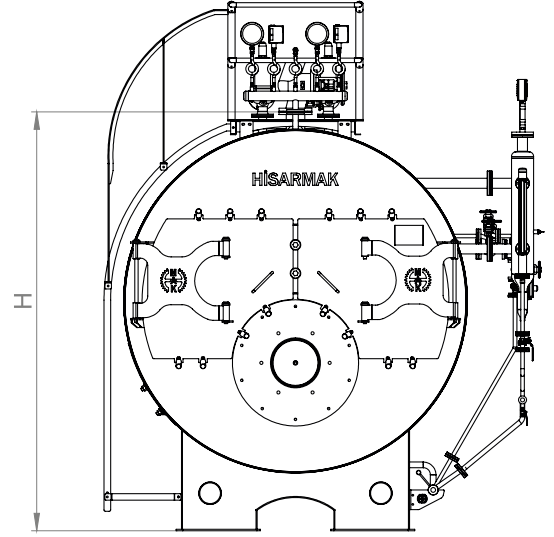
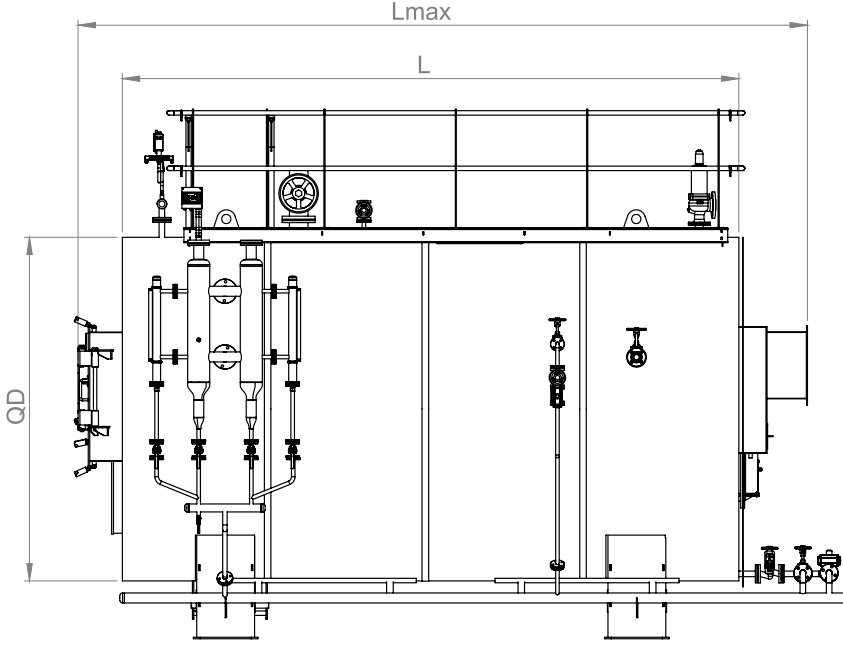

SKOÇ TİPİ KAZAN TEKNİK ÖLÇÜLERİ

SCOTCH TYPE BOILER TECHNICAL MEASUREMENTS

| TIP (Type) | BUHAR KAPASİTESİ (Steam Capacity) Ton/H | ISITMA YÜZEYİ (Heating Surface) m ² | KAPASİTE (Capacity) kW/H | ÇALIŞMA BASINCI (Operating Pressure) Bar-Psi | BACA ÇAPİ (Diameter of Chimney) mm | BUHAR ÇIKIŞI (Steam Output) DN | EMNİYET VENTİLİ (Safety Valve) DN | KAZAN AĞIRLIK (Boiler Weight) Kg | KAZAN ÖLÇÜLERİ (Boiler Sizes) | | | |
|---------------|---|--|--------------------------------|--|--|--------------------------------------|---|--|----------------------------------|------|------|--------|
| | | | | | | | | | QD | H | L | L max. |
| HSBK 1000 | 1 | 25 | 697 | 8 | 350 | 65 | 32 | 2800 | 1700 | 1800 | 2000 | 2500 |
| HSBK 2000 | 2 | 50 | 1395 | 8 | 420 | 80 | 40 | 4000 | 1900 | 2200 | 2200 | 3100 |
| HSBK 3000 | 3 | 75 | 2080 | 8 | 480 | 80 | 40 | 7400 | 2300 | 2500 | 2800 | 3500 |
| HSBK 4000 | 4 | 100 | 2790 | 8 | 530 | 100 | 50 | 9500 | 2500 | 2800 | 3300 | 4200 |
| HSBK 5000 | 5 | 125 | 3488 | 8 | 560 | 100 | 50 | 10500 | 2560 | 3100 | 4200 | 5300 |
| HSBK 6000 | 6 | 150 | 4168 | 8 | 700 | 125 | 50 | 12000 | 2650 | 3100 | 5300 | 6100 |
| HSBK 8000 | 8 | 200 | 5581 | 8 | 750 | 150 | 65 | 15200 | 2800 | 3200 | 6300 | 7100 |
| HSBK10000 | 10 | 250 | 6976 | 8 | 800 | 200 | 80 | 18000 | 3100 | 3550 | 6700 | 7700 |
| HSBK 12000 | 12 | 300 | 8372 | 8 | 920 | 200 | 80 | 22000 | 3200 | 3600 | 6800 | 8050 |
| HSBK 15000 | 15 | 375 | 10465 | 8 | 950 | 200 | 100 | 27000 | 3250 | 3700 | 7050 | 9500 |
| HSBK 20000 | 20 | 500 | 13953 | 8 | 1000 | 200 | 100 | 31000 | 3300 | 3850 | 7500 | 9000 |
| HSBK 25000 | 25 | 625 | 17441 | 8 | 1200 | 250 | 100 | 42000 | 3400 | 3850 | 8100 | 9700 |



BUHAR KAZANI

Kapasite Aralığı: 3-25 Ton/saat buhar
Basınç: 0-25 Bar
Yakıt: 5-14 mm linyit kömür, biyokütle, endüstriyel atıklar

SICAK SU KAZANI

Kapasite Aralığı: 3.000 -12.000 kw/saat
Sıcaklık: 90-120°C
Yakıt: 5-14 mm linyit kömür

STEAM BOILER

Capacity Range: 3-25 Ton/h steam
Pressure: 0-25 Bar
Fuel: 5-14 mm lignite coal, biomass, industrial wastes

HOT WATER BOILER

Capacity Range: 3.000 -12.000 kw/h
Temperature: 90-120°C
Fuel: 5-14 mm lignite coal

Özellikler

TR Katı yakıtlı kazan sistemlerinde özellikle kömür, biyokütle, biomass, endüstriyel atıkların ve benzeri yakıtların yüksek verimle yakılması için geliştirilmiş ileri teknolojiye sahip yakma sisteminin kullanıldığı kazanlardır.

Çalışma Prensibi

Yanma sisteminde kömür, servis bunkerinden ızgaraya döküldüğü andan itibaren ocak içerisine doğru ızgaranın dönme hızı ile ilerler.

Ocağa ilk girdiği anda, radyasyon ısısının etkisiyle kömür önce nemini salmaya, sıcaklığın artmasıyla gazlaşmaya ve uçucu-yanıcı hidrokarbonlarını salmaya baslar ve ızgaranın ilerleyen kısımlarında sabit karbon yanmasını tamamlar. Kömürün tüm bileşenlerinin ızgaranın sonuna kadar yanması devam eder.

Yanma tam olarak bittiği için kalan cüruf miktarı çok azdır ve bu da cüruf teknesine dökülür ve dışarı alınır.

Kömürün bunkerlere yüklenmesi, yakılması ve cürufun deşarjına kadar olan tüm işlemler PLC otomasyon sistemi ile tam otomatik olarak gerçekleşmektedir.

Sertifikalar

PED 2014/68/EU ve ilgili uluslararası basınçlı ekipman standartlarına uygun olarak tasarlanmış ve üretilmiştir.

Features

EN These are boilers equipped with advanced combustion systems specifically developed for the high-efficiency burning of solid fuels such as coal, biomass, biowaste, industrial waste, and similar fuels.

Working Principle

In the combustion system, coal begins to move toward the furnace as soon as it is discharged onto the grate from the service bunker, progressing with the rotation speed of the grate.

Upon entering the furnace, the coal first releases its moisture due to the effect of radiant heat, then begins to gasify as the temperature increases, releasing volatile combustible hydrocarbons. In the following sections of the grate, the fixed carbon combustion is completed. The combustion of all components of the coal continues until the end of the grate. Since combustion is completed fully, the amount of remaining ash (slag) is minimal. This ash falls into the slag tray and is discharged.

All processes from loading coal into the bunkers, to combustion, to slag discharge are carried out fully automatically via a PLC automation system.

Certificates

Designed and manufactured in compliance with PED 2014/68/EU and relevant international pressure equipment standards.

Döner Izgaralı Yakma Sistemleri

Rotary Grate Combustion Systems

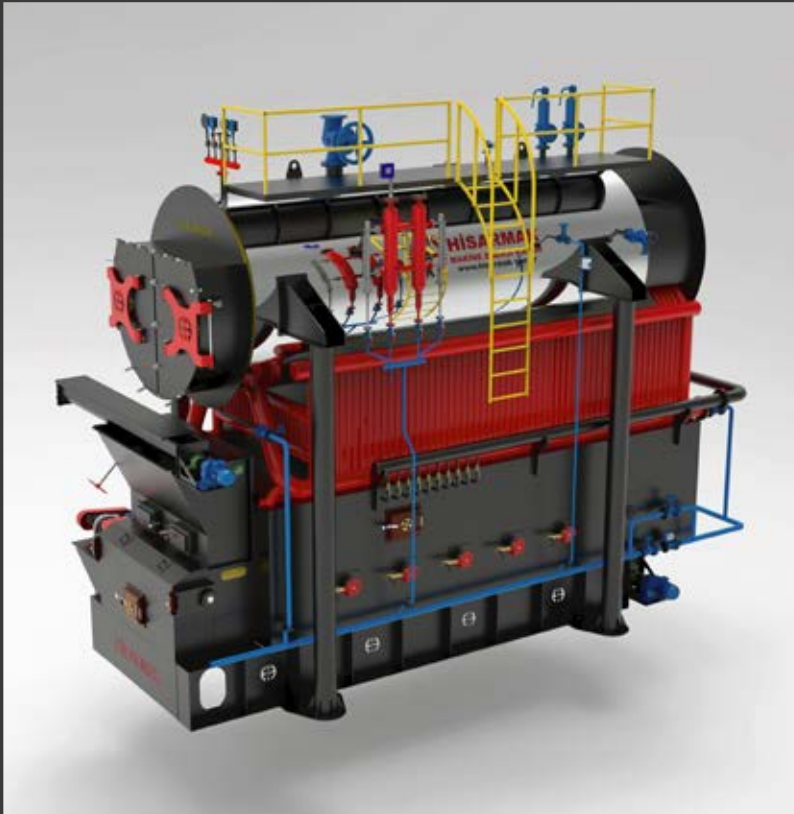



Kapasite Aralığı: 5-60 Ton/saat buhar
Basınç: 0-25 Bar
Yakıt: Kömür ve endüstriyel atıklar
Avantaj: %90 Yanma verimi
Filtrasyon: Elektrostatik ve torbalı filtre seçeneği

Capacity Range: 5-60 Ton/h steam
Pressure: 0-25 Bar
Fuel: Coal and industrial waste
Advantage: %90 Burning efficiency
Filtration: Electrostatic and bag filter option

Özellikler

TR Akışkan yataklı kazanlarımız, düşük kalorili ve yüksek kül oranlı linyit kömürlerini %85 verimle yakabilir. Bubbling ve sirkülayonlu tipleri mevcuttur. Kullanılan filtre sistemleri sayesinde emisyonlar çevre yönetmeliklerine uygundur.

Çalışma Prensipleri

Sistemde ince taneli katı yakıtlar (kömür, biyokütle, odun vb.) ve yardımcı maddeler homojen şekilde karıştırılır. Alttan üflenen hava, yatak içinde kabarcıklı bir yapı oluşturarak yüksek verimli yanma ve ısı transferi sağlar. Bu teknoloji, düşük kaliteli yakıtları toz haline getirmeden verimli şekilde yakar.

Sertifikalar

PED 2014/68/EU ve ilgili uluslararası basınçlı ekipman standartlarına uygun olarak üretilmiştir.

Features

Z Our fluidized bed boilers burn low-calorific, high-ash lignite coals with 85% efficiency. Available in bubbling and circulating types. Filtration systems used in these boilers ensure compliance with emission regulations.

Working Principle

Fine solid fuels (coal, biomass, wood, etc.) and additives are mixed homogeneously. Air blown from below creates a bubbling bed for efficient combustion and heat transfer. This technology burns low-grade fuels efficiently without pulverization.

Certificates

Manufactured in accordance with PED 2014/68/EU and relevant international pressure equipment standards.

Akışkan Yataklı Kızgın Yağ Kazanı

Fluidized Bed Thermal Oil Boiler



AKIŞKAN YATAKLI KIZGIN YAĞ KAZANI

| | |
|------------------------------|--|
| Kapasite Aralığı: | 3-15.000.000 KCAL kızgın yağ |
| Kızgın Yağ Sıcaklığı: | 0-270 °C |
| Yakıt: | 0-16mm (1.500-6.000 kcal) aralığında kömür |
| Avantaj: | %90 Yanma verimi |
| Filtrasyon: | Elektrostatik ve torbalı filtre seçeneği |

AKIŞKAN YATAKLI KOMBİNE KAZANI

| | |
|-------------------------------|--|
| Kapasite Aralığı: | 5-20 Ton/saat buhar |
| Kızgın Yağ Kapasitesi: | 2-10.000.000 KCAL kızgın yağ |
| Basınç: | 0-8 Bar |
| Kızgın Yağ Sıcaklığı: | 0-270 °C |
| Yakıt: | 0-16mm (1.500-6.000 kcal) aralığında kömür |
| Avantaj: | %90 Yanma verimi |
| Filtrasyon: | Elektrostatik ve torbalı filtre seçeneği |

Özellikler

TR Akışkan yataklı kızgın yağ kazanlarımız düşük kalorili, yüksek kül oranında linyit kömürleri %85 verimle yakabilen bir sisteme sahip kazan çeşididir. Özellikle yağ, tekstil, kimya gibi yüksek sıcaklık gerektiren proseslerde kullanılmaktadır. Bubbling ve sirkülasyonlu tiplerini üretmekteyiz. Kullanılan filtre sistemleri sayesinde partikül ve gaz salınımı olarak çevre yönetmeliği standartlarına uygundur.

Sertifikalar

PED 2014/68/EU ve ilgili uluslararası basınçlı ekipman standartlarına uygun olarak tasarlanmış ve üretilmiştir.

FLUIDIZED BED COMBINED BOILER

| | |
|-----------------------------|---|
| Capacity Range: | 3-15.000.000 KCAL hot oil |
| Hot Oil Temperature: | 0-270 °C |
| Fuel: | 0-16mm (1.500-6.000 kcal) coal in range |
| Advantage: | %90 Burning efficiency |
| Filtration: | Electrostatic and bag filter option |

FLUIDIZED BED HOT OIL BOILER

| | |
|-----------------------------|---|
| Capacity Range: | 5-20 Ton/h steam |
| Hot Oil Capacity: | 2-10.000.000 KCAL hot oil |
| Pressure: | 0-8 Bar |
| Hot Oil Temperature: | 0-270 °C |
| Fuel: | 0-16mm (1.500-6.000 kcal) coal in range |
| Advantage: | %90 Burning efficiency |
| Filtration: | Electrostatic and bag filter option |

Features

EN Our fluidized bed thermal oil boilers are designed to burn low-calorific, high-ash lignite coals with up to 85% efficiency. These boilers are particularly used in high-temperature processes such as in the oil, textile, and chemical industries. We manufacture both bubbling and circulating types. Thanks to the filtration systems used, the boilers comply with environmental regulation standards in terms of particulate and gas emissions.

Certificates

Designed and manufactured in compliance with PED 2014/68/EU and relevant international pressure equipment standards.





Kapasite Aralığı: 10-100 Ton/saat buhar
Basınç: 0-25 Bar
Buhar Sıcaklığı: 120-500 °C
Yakıt: Biokütle ve çeşitli atıklar

Capacity Range: 10-100 Ton/h steam
Pressure: 0-25 Bar
Steam Temperature: 120-500 °C
Fuel: Biomass and various wastes

Özellikler

TR Biyokütle ve endüstriyel atıklar, hareketli ızgaralı sistemlerle yüksek verimle buhar enerjisine dönüştürülür. Kazanlarımız Avrupa'da güvenle kullanılmakta olup uzun ömürlü ve yüksek verimlidir.

Sistemde enerjiye dönüştürülebilen başlıca kaynaklar:

- Orman ve tarım atıkları
- Endüstriyel atıklar
- Arıtma çamuru, hayvansal gübre
- RDF ve ağaç sanayi atıkları

Sertifikalar

PED 2014/68/EU ve uluslararası basınçlı ekipman standartlarına uygundur.

Features

ZU Biomass and industrial waste are efficiently converted into steam using moving grate systems. Our boilers are widely used in Europe, offering high efficiency and long service life.

Main energy sources include:

- Forest and agricultural waste
- Industrial residues
- Sludge, animal manure
- RDF and wood industry waste

Certificates

Complies with PED 2014/68/EU and international pressure equipment standards.

Biyokütle ve Biomass Yakıtlı Buhar Kazanları

Biomass Fueled Steam Boilers





İleri İtimli Buhar Kazanı

Moving Grate Steam Boiler



Kapasite Aralığı: 0-15 Ton/saat buhar
Basınç: 0-15 Bar
Yakıt: 0-60mm kömür
Avantaj: Düşük yatırım maliyeti
Baca: Düşük baca duman emisyonu

Capacity Range: 0-15 Ton/h steam
Pressure: 0-15 Bar
Fuel: 0-60mm coal
Advantage: Low investment cost
Chimney: Low flue smoke emission

Özellikler

TR Hisarmak tarafından geliştirilen ileri itimli, PLC kontrollü tam otomatik buhar kazanları; otomatik yakıt besleme, kül ve curuf çıkarma gibi sistemlerle maksimum kullanıcı konforu sunar.

Basınca ve baca sıcaklığına duyarlı hareketli ızgara kontrolü, oransal çalışma prensibiyle birleşerek tam yanma sağlar.

Sistem; Cebri Çekiş, Vakum ve Otomatik Yanma olmak üzere üç farklı modda çalışabilir. İç basınca göre taze hava fanı otomatik devreye girerek sistemin kendi kendini dengelemesini sağlar.

Bu akıllı yapı, yüksek verim ve yakıt tasarrufu sağlarken, baca gazı emisyonları da çevre standartlarının altında kalır.

Features

Z Developed by Hisarmak, the advanced forward-moving, PLC-controlled fully automatic steam boilers offer maximum comfort through systems like automatic fuel feeding and ash/slag removal.

The grate control, responsive to pressure and flue gas temperatures, works with a proportional operating system to ensure complete combustion.

It operates in three modes: Forced Draft, Vacuum, and Automatic Combustion. The fresh air fan is activated based on internal boiler pressure, allowing self-balancing operation.

This intelligent setup provides high efficiency and fuel savings while maintaining flue gas emissions below environmental standards.



İleri İtimli Buhar Kazanı Moving Grate Steam Boiler



AD 2000
Merkblatt





Stokerli ve Otomatik Yüklemeli Buhar Kazanı

Stoker and Automatic Fuel Loading Steam Boiler



Kapasite Aralığı: 0-10 Ton/saat buhar
Basınç: 0-15 Bar
Yakıt: 0-25mm kömür
Avantaj: Düşük yatırım maliyeti, az yerleşke alanı

Capacity Range: 0-10 Ton/h steam
Pressure: 0-15 Bar
Fuel: 0-25mm coal
Advantage: Low investment cost, small footprint

Özellikler

TR Stoker, kömür, pelet veya odun gibi katı yakıtların kazan içine otomatik veya yarı otomatik beslenmesini sağlayan mekanizmadır. Bu sistem, sürekli ve dengeli yakıt beslemesi ile daha verimli ve kararlı bir yanma sağlar. Yanma odasında oluşan ısı, suyu buhara çevirerek tesisin ısıtma ve proses ihtiyaçlarını karşılar.

Çalışma Prensibi

Yanma sonucu oluşan sıcak gazlar, önce yanma odasından (birinci geçiş), sonra ön kısımdaki ikinci duman borularına yönelir. Burada toplanan gazlar siklona gönderilir ve ardından bacadan dışarı atılır. Üstten yanma prensibi ile tam yanma sağlanır; bu da sistemi çevre dostu kılar.

Sertifikalar

TS EN 12953 standardına uygun olarak CE sertifikalıdır.

Features

EN The stoker is a mechanism that allows automatic or semi-automatic feeding of solid fuels such as coal, pellets, or wood into the boiler. With continuous and balanced feeding, combustion becomes more stable and efficient. The heat generated turns water into steam for use in process or heating systems within the facility.

Working Principle

Combustion gases first pass through the combustion chamber (first pass), then move to the second pass smoke tubes at the front. The gases are collected, sent to the cyclone, and finally released through the chimney. Thanks to top-down combustion, full coal combustion is achieved, making the system environmentally friendly.

Certificates

CE certified in accordance with TS EN 12953 standard.



Stokerli ve Otomatik Yüklemeli Sıcak Su Kazanı

Stoker and Automatic Fuel Loading Hot Water Boiler



Kapasite Aralığı: 5-10 Ton/saat buhar
Basınç: 0-15 Bar
Yakıt: 0-25mm kömür
Avantaj: Düşük yatırım maliyeti, az yerleşke alanı

Capacity Range: 5-10 Ton/h steam
Pressure: 0-15 Bar
Fuel: 0-25mm coal
Advantage: Low investment cost, small footprint

Özellikler

TR Stokerli sıcak su kazanı, kömür veya biyokütle gibi katı yakıtları mekanik sistemle yanma odasına otomatik olarak besleyen bir ısıtma sistemidir. Helezon tipi yakıt taşıyıcı sistemle düzenli ve verimli yakıt akışı sağlanır. Otomatik besleme sayesinde sürekli çalışma mümkün olurken, manuel müdahale gereksinimi en aza iner.

Gelişmiş kontrol sistemleri sayesinde yanma parametreleri izlenip optimize edilir. Stoker mekanizması yüksek ısı verim sağlar. Kömür, odun, biyokütle gibi farklı yakıt türleriyle uyumlu çalışır.

Kül çıkarma işlemi genellikle manuel olmakla birlikte, bakım kolaylığı için entegre sistemler eklenebilir.

Sertifikalar

TS EN 12953 standardına uygun CE sertifikalıdır.

Features

EN A stoker hot water boiler transfers solid fuels like coal or biomass into the combustion chamber via a mechanical system. The screw feeder ensures smooth and efficient fuel flow. With automatic feeding, the system offers continuous operation and minimal manual intervention.

Advanced control systems monitor and adjust combustion parameters for optimal performance. The stoker mechanism contributes to high thermal efficiency. The boiler is compatible with various fuels including coal, wood, and biomass.

While ash removal is often manual, optional integrated systems may simplify maintenance.

Certificates

CE certified in accordance with TS EN 12953 standard.





Sıvı & Gaz Yakıtlı Skoç Tipi Sıcak Su Kazanları

Scotch Type Hot Water Boilers with Liquid & Gas Fuel



Özellikler

TR Hisarmak sıcak su kazanları, enerji verimliliği ve uzun ömürlü kullanım odaklı mühendislik tasarımıyla öne çıkar:

- 6–8 bar işletme basıncı aralığında güvenli ve stabil çalışma
- %94,4'e varan yüksek verim ile enerji kayıplarının en aza indirilmesi
- Üç geçişli yanma prensibi, duman gazlarının dengeli soğuması ve her geçişte kesintisiz akış sayesinde uzun kazan ömrü
- Optimum termik dengeleme ve etkin ısı transferi ile düşük işletme maliyetleri
- Simetrik yerleşimli ısı transfer yüzeyleri ile yüksek dayanımlı kazan konstrüksiyonu
- Düşük baca gazı emisyonları sayesinde çevre yönetmeliklerine tam uyum
- Homojen sıcaklık dağılımı sağlayan entegre ejektör açıklıkları ve dönüş suyunu sıcak bölgelere yönlendiren özel plakalar ile yüksek işletme güvenliği
- Su soğutmalı cehennemlik yapısı ile maksimum ısı transferi ve sistem koruması
- Paslanmaz malzeme ile üretilmiş ekonomizör bölümü, yoğuşma kaynaklı asidik etkilerin sistem üzerinde oluşturabileceği zararı ortadan kaldırır.

Bu kazan sistemi güvenilir performans, daha düşük emisyon ve uzun vadeli tasarruf sağlamak üzere tasarlanmıştır.

Features

EN Hisarmak hot water boilers stand out with engineering and design focused on energy efficiency and long-lasting performance;

- Safe and stable operation within 6–8 bar operating pressure range
- High efficiency up to 94.4%, minimizing energy losses
- Three-pass combustion principle ensures balanced flue gas cooling and uninterrupted flow at each stage, extending boiler lifespan
- Optimal thermal balancing and effective heat transfer reduce operational costs
- High-durability boiler construction with symmetrically arranged heat transfer surfaces
- Full compliance with environmental regulations thanks to low flue gas emissions
- Integrated ejector openings and special plates directing return water to hot zones ensure even temperature distribution and high operational safety
- Water-cooled furnace structure provides maximum heat transfer and system protection
- Stainless steel economizer section eliminates damage from condensation-induced acidic effects.

This boiler system is designed to deliver reliable performance, lower emissions, and long-term savings.



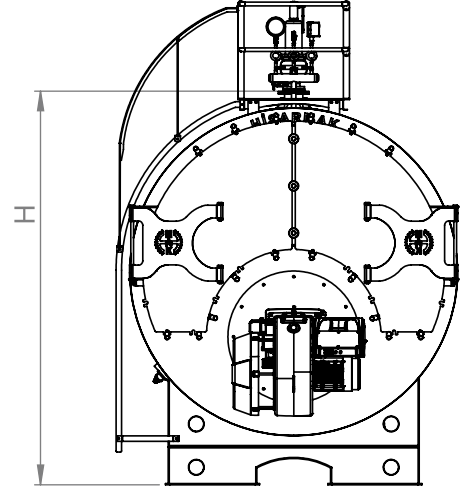
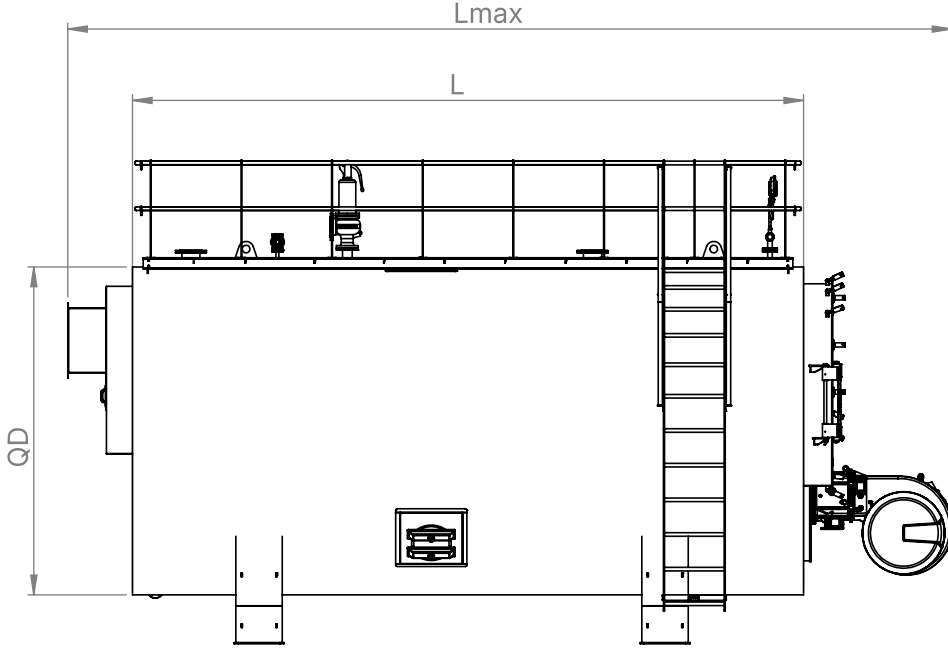

SKOÇ TİPİ SICAK SU KAZANI TEKNİK BİLGİLERİ

SCOTCH TYPE HOT WATER BOILER TECHNICAL INFORMATION

| Tip (Type) | Kapasite (Capacity) | Kapasite (Capacity) | Su Sıcaklığı (Water Temp.) | Çalışma Basıncı (Working Pressure) | Su Girişi/Çıkışı (Water Inlet/Outlet) | Ölçü (Dimension) mm. | | | Ağırlık (Weight) |
|---------------|------------------------|------------------------|-------------------------------|---|--|----------------------------|------|------|---------------------|
| | Kcal/h | Kw | Max. °C | Bar | DN | D | L | H | Kg. |
| HSSK 1250 | 1.250.000 | 1453 | 90 | 6 | 125 | 1750 | 3700 | 2100 | 5600 |
| HSSK 1500 | 1.500.000 | 1744 | 90 | 6 | 125 | 1850 | 4000 | 2200 | 6000 |
| HSSK 2000 | 2.000.000 | 2325 | 90 | 6 | 150 | 2000 | 4300 | 2400 | 7200 |
| HSSK 2250 | 2.250.000 | 2616 | 90 | 6 | 150 | 2050 | 4350 | 2450 | 8200 |
| HSSK 2500 | 2.500.000 | 2906 | 90 | 6 | 200 | 2150 | 4550 | 2500 | 8700 |
| HSSK 3000 | 3.000.000 | 3488 | 90 | 6 | 200 | 2150 | 4750 | 2500 | 9000 |
| HSSK 4000 | 4.000.000 | 4651 | 90 | 6 | 200 | 2400 | 5200 | 2750 | 13000 |
| HSSK 5000 | 5.000.000 | 5813 | 90 | 6 | 200 | 2500 | 5500 | 3000 | 14100 |
| HSSK 6000 | 6.000.000 | 6976 | 90 | 6 | 250 | 2800 | 5800 | 3300 | 17500 |
| HSSK 8000 | 8.000.000 | 9302 | 90 | 6 | 250 | 3000 | 6000 | 3500 | 21000 |



Elektrikli Buhar Jeneratörleri

Electric Steam Generators



Özellikler

TR Hisarmak tarafından geliştirilen elektrikli buhar jeneratörleri, elektrik enerjisini doğrudan buhar gücüne dönüştüren, çevreci ve yüksek verimli sistemlerdir.

500 kg/saat ile 3.000 kg/saat aralığında buhar üretim kapasitesine sahip olan sistemlerimiz, kullanıcı ihtiyaçlarına göre 1 ila 8 bar arasında farklı çalışma basınçlarında tasarlanabilmektedir. Modern sanayi tesislerinin sürdürülebilir üretim hedeflerine güçlü bir çözümdür.

Atık gaz üretmeyen bu sistemler, sıfır emisyon değeriyle çevresel sürdürülebilirlik hedeflerine katkı sağlar. Su ve elektrik enerjisinin entegre kontrol sistemiyle buhara dönüştürülmesi sayesinde, işletmelerin buhar ihtiyacı güvenilir, sessiz ve temiz bir şekilde karşılanır.

Features

EN The electric steam generators developed by Hisarmak are eco-friendly and high-efficiency systems that directly convert electrical energy into steam power.

With a steam production capacity ranging from 500 kg/h to 3,000 kg/h, our systems can be designed to operate at various pressure levels between 1 and 8 bar to meet user requirements. These systems offer a powerful solution for modern industrial facilities aiming for sustainable production goals.

Since they produce no waste gases, they contribute to environmental sustainability with zero emissions. Thanks to the integrated control system that efficiently manages water and electricity conversion into steam, the steam needs of facilities are met in a reliable, silent, and clean manner.



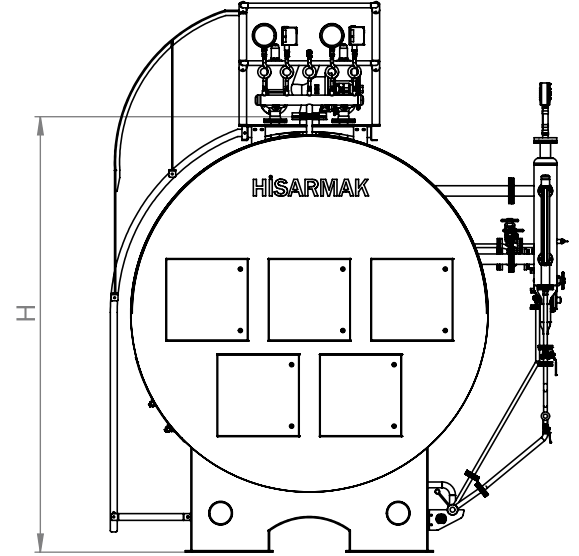
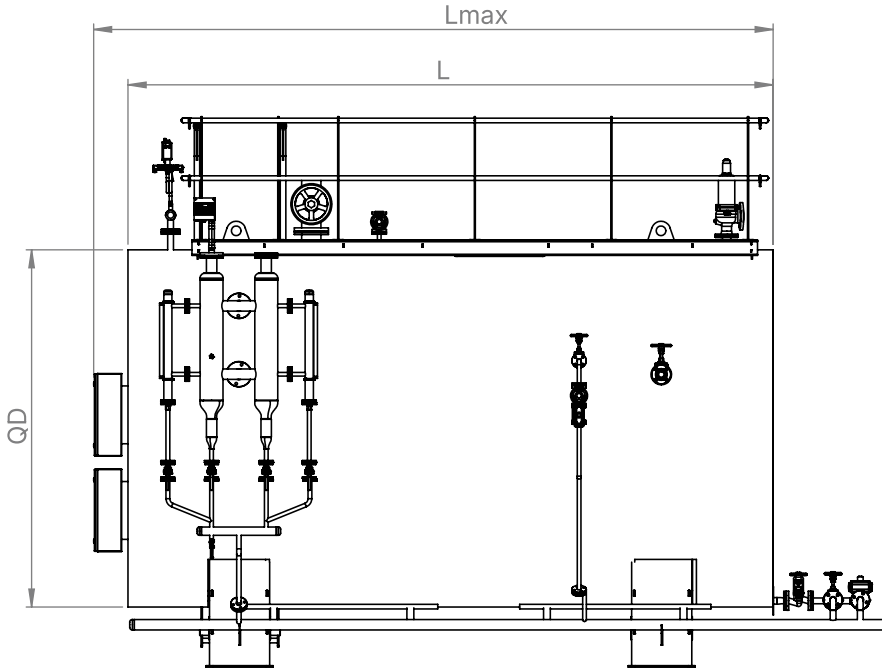

ELEKTRİKLİ BUHAR JENERATÖRÜ TEKNİK BİLGİLERİ

ELECTRIC STEAM GENERATOR TECHNICAL INFORMATION

| Tip Type | Buhar Kapasite Steam Capacity | Kapasite Capacity | Çalışma Basıncı Working Pressure | Ölçü Dimension mm. | | | Ağırlık Weight |
|-------------|--|----------------------|---|--------------------------|---|---|-------------------|
| | Kg/h | Kw | Bar | D | L | H | Kg. |
| HEBJ 1000 | 1000 | 697 | 8 | | | | |
| HEBJ 1500 | 1500 | 1046 | 8 | | | | |
| HEBJ 2000 | 2000 | 1395 | 8 | | | | |
| HEBJ 2500 | 2500 | 1744 | 8 | | | | |
| HEBJ 3000 | 3000 | 2093 | 8 | | | | |



Özellikler

TR Kondens tankı (yoğuşma tankı veya kondens toplama tankı olarak da bilinir), buhar hatlarından gelen yüksek sıcaklıktaki suyun toplandığı, belli bir seviyeye kadar depolandığı ve tekrar sisteme kazandırıldığı özel bir tanktır.

Çalışma Prensibi

Kondens tankı, buhar kullanım noktasından geri dönen sıcak suyu (kondensi) biriktirir. İçerisindeki seviye kontrolü ve basınçlı hatlar sayesinde bu su, kazan besli hattına veya ekonomizer gibi ek ısı geri kazanım sistemlerine yönlendirilebilir. Böylelikle sistemdeki su, tekrar kullanıma hazır hale gelir.

Features

EN TA condensate tank (also known as a condensate collection tank or condensate return tank) is a specialized tank used to collect and store high-temperature water (condensate) returning from steam lines. It stores this water up to a certain level and then redirects it back into the system.

Working Principle

The condensate tank collects hot water (condensate) returning from steam usage points. With internal level control systems and pressurized lines, this water can be redirected to the boiler feed line or to additional heat recovery systems like an economizer. This process allows the water to be reused, increasing overall system efficiency and reducing energy and water consumption.



Özellikler

TR Degazör tankı, kazan besi suyunda çözülmüş halde bulunan oksijen (O_2) ve karbondioksit (CO_2) gibi gazları fiziksel veya kimyasal yöntemlerle uzaklaştırmak için kullanılan önemli bir ekipmandır. Bu ekipmanın temel amacı, sistemdeki korozyonu önlemek ve kazan ömrünü uzatmaktır.

Çalışma Prensibi

Degazör tankı, buhar ve suyun doğrudan temas ettiği bir ortam oluşturarak, su içindeki istenmeyen gazların uzaklaştırılmasına yardımcı olur. Böylece kazan iç yüzeyleri ve bağlı sistem ekipmanları korozyona karşı korunmuş olur.

Besi Suyunun Ön Isıtılması: Tanka giren su öncelikle belirli bir sıcaklığa kadar ısıtılır. Bu ısı artışı, sudaki O_2 ve CO_2 gibi gazların çözünürlüğünü azaltır.

Gazların Ayrılması ve Tahliyesi: Gazlar buhar fazına geçer ve tankın üst kısmındaki özel egzoz hattı sayesinde sistem dışına atılır. Bu iki aşama sayesinde, kazana gönderilen suyun içerdiği korozyon yapıcı gazlar minimum seviyeye düşürülmüş olur.

Features

EN A deaerator tank is an essential unit designed to remove dissolved gases such as oxygen (O_2) and carbon dioxide (CO_2) from boiler feedwater using physical or chemical processes. The main goal is to prevent internal corrosion and extend the service life of the boiler system.

Working Principle

The deaerator tank enables direct contact between steam and water, which helps remove unwanted gases from the feedwater. This protects the inner surfaces of the boiler and its components from corrosive effects.

Preheating the Feedwater: Water entering the tank is first heated to a specific temperature. This reduces the solubility of gases like O_2 and CO_2 in the water.

Separation and Venting: The released gases transition into the vapor phase and are discharged from the system through a dedicated exhaust line at the top of the tank. As a result, oxygen and carbon dioxide levels in the feedwater are minimized, lowering the risk of corrosion in the boiler.



Özellikler

TR Torba filtre sistemleri, sanayi tesislerinden çıkan toz ve partikülleri çevreye salınmadan önce tutmak için tasarlanmış çevreci filtreleme ekipmanlarıdır. Bu sistemler, güçlü emiş gücüne sahip fanlar sayesinde kirli havayı kaynaktan çeker ve filtre ünitesine yönlendirir. Genellikle çok katmanlı dokuma veya keçeden yapılmış özel filtre torbaları kullanılır. Bu torbalar, havadaki tozların etkili şekilde tutulmasını sağlar ve temiz havanın geçişine izin verir.

Çalışma Prensipleri

Torba filtre sistemleri, yüzey filtrasyonu prensibiyle çalışır. Toz yüklü hava, filtre ünitesinin içine çekilir. Hava içerisindeki partiküller torbaların dış yüzeyine yapışır ve burada tutulur. Temiz hava ise torba malzemesinden geçerek dışarı atılır veya sistem yapısına göre yeniden üretim sürecine yönlendirilir. Bu yöntem, yüksek verimle toz ayrımı yapar ve sanayilerin çevre yönetmeliklerine uyumunu sağlar.

Kullanım Alanları

- Tekstil
- Gıda
- Yem
- Bulgur
- Kireç
- Kömürle çalışan endüstriyel tesisler

Features

EN Bag filter systems are eco-friendly filtration units designed to capture dust and particulate matter generated by industrial operations before it is released into the environment. These systems use high-suction fans to draw in contaminated air from the source and transport it to a filtration chamber. Multi-layer woven or felt filter bags are typically used. These specialized bags effectively trap airborne particles while allowing clean air to pass through.

Working Principle

Bag filters operate based on the principle of surface filtration. Dust-laden air is drawn into the filter unit. Particles in the air are captured and held on the external surface of the filter bags. The clean air then passes through the filter material and is either released into the atmosphere or redirected to the production process depending on system design. This method ensures efficient dust separation and helps facilities comply with environmental regulations.

Areas of Usage

- Textile
- Food
- Feed
- Bulgur
- Lime
- Coal-fired industrial plants





Özellikler

TR Ekonomizer, duman gazlarının sıcaklığını düşürerek içerdikleri artık ısıyı geri kazanmak ve yakıt tüketimini azaltmak için tasarlanmış bir ısı geri kazanım ekipmanıdır. Buhar, ısı ve enerji üretim tesislerinde, kazanlardan çıkan egzoz gazlarının bacaya gitmeden önceki kısmına yerleştirilir. Burada bacaya gitmeden önceki sıcak gazlardaki ısının bir bölümü geri kazanılır.

Çalışma Prensipleri

Kazanda yakıtın yanması sonucunda yüksek sıcaklıkta duman gazı oluşur. Bu gazlar, baca yönünde ilerlerken ekonomizerden geçer. Ekonomizerin içinde bu sıcak gazlar, ısı transfer yüzeyleri (kanatlı ya da düz borular) üzerinden geçer. Aynı anda bu boruların içerisinden kazan besisi suyu veya proses suyu ters akış ya da paralel akış prensibiyle geçer.

Sıcak gaz, içinden geçtiği borulardaki suya ısını aktararak sıcaklığını düşürürken, su da ısınarak ön ısıtılmış hale gelir. Bu ön ısıtılmış su, kazana gönderilerek buhar üretiminde kullanılır. Böylece;

- Yakıt tüketimi azalır
- Kazan verimliliği artar
- İşletme maliyeti düşer
- Çevresel etki azalır

Features

EN An economizer is a heat recovery element that reduces the flue gas temperature and recovers its residual heat to lower fuel consumption. It is widely used in steam, heat, and power generation systems and is installed in the flue gas path before the exhaust gases reach the chimney. At this stage, a portion of the heat contained in the hot flue gases is recovered.

Working Principle

When fuel is burned in the boiler, high-temperature flue gases are generated. As these gases move toward the chimney, they pass through the economizer. Inside the economizer, the gases flow over heat transfer surfaces (either finned or plain tubes). At the same time, feedwater or process water flows inside the tubes in a counterflow or parallel arrangement.

As the gases transfer their heat to the water flowing through the tubes, their temperature decreases while the water temperature increases. The preheated water is then sent into the boiler for steam generation. As a result:

- Fuel usage is reduced
- Boiler efficiency improves
- Operating costs are lowered
- Environmental impact is minimized

Katı Yakıtlı Kazan Ekonomizeri

Solid Fuel Boiler Economizer



Özellikler

TR Katı yakıtlı kazan ekonomizeri, katı yakıtlı kazanlarda oluşan yüksek sıcaklıktaki baca gazlarının içerdiği atık ısının geri kazanılması için kullanılan bir ısı geri kazanım ekipmanıdır. Baca hattına yerleştirilerek gaz enerjisinin bir kısmını kazan besisi suyuna aktarır.

Kömür yanmasına bağlı oluşan kül ve partikül yüküne dayanıklı, geniş yüzey alanlı ve kolay temizlenebilir yapıda tasarlanmıştır.

- Yakıt tüketimini azaltır
- Kazan verimini artırır
- İşletme maliyetlerini düşürür
- Baca gazı sıcaklığını düşürür
- Çevresel etkiyi azaltır

Çalışma Prensipleri

Kazan içerisinde kömürün yanması sonucu oluşan sıcak baca gazları, bacaya gitmeden önce ekonomizerden geçirilir. Gazlar boru yüzeylerinden geçerken, borular içindeki besisi suyuna ısı aktarır.

Isınan besisi suyu kazana gönderilir ve sistem daha az yakıtla daha verimli çalışır.

Features

EN The Solid Fuel Boiler Economizer is a heat recovery equipment designed to utilize the waste heat contained in high-temperature flue gases generated in solid fuel-fired boilers. Installed in the flue gas line, it transfers a portion of the gas energy to the boiler feedwater.

The unit is designed to withstand dust and ash conditions with a durable structure and large heat transfer surface.

- Reduces fuel consumption
- Increases boiler efficiency
- Lowers operating costs
- Reduces flue gas temperature
- Minimizes environmental impact

Working Principle

Hot flue gases generated during coal combustion pass through the economizer before reaching the chimney. The gases transfer their heat to the feedwater flowing inside the tubes.

The preheated water is then sent to the boiler, improving overall efficiency and reducing fuel consumption.



Özellikler

Endüstriyel tesislerden çıkan atık gazların temizlenmesi ve çevreye zarar vermeden atmosfere salınmasını sağlayan ileri düzey bir hava arıtma sistemidir. Bu sistem, gazların kimyasal içeriğine göre seçilen sıvılarla yıkanarak, zararlı maddelerin ayrıştırılmasını ve doğaya zarar vermeden havaya salınmasını mümkün kılar.

Çalışma Prensipleri

Bacadan çıkan toz ve gaz kirlenmeleri sıvı (çoğunlukla su) ile temas ettirerek temizler.

Kirlenmeler, gaz akımı içindeki su partikülleri veya özel kimyasal çözeltilerle reaksiyona girerek yakalanır ve çözüldüğü tutulur.

Temizlenen gaz akımı ise bacadan çıkar.

Features

A wet filter is an advanced air purification system that cleans exhaust gases from industrial facilities and ensures they are released into the atmosphere without harming the environment. In this system, gases are washed with liquids selected according to their chemical content, allowing harmful substances to be separated and safely released into the air without damaging nature.

Working Principle

Exhaust gases from the chimney are cleaned by being brought into contact with a liquid (usually water).

The pollutants in the gas flow react with water particles or special chemical solutions and are trapped and held in the solution.

The cleaned gas flow exits through the chimney.

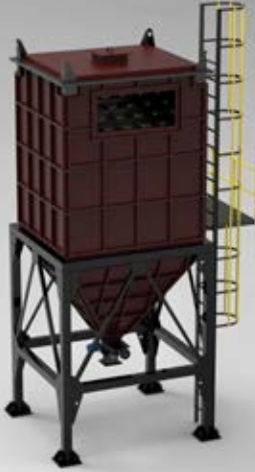

Özellikler

Duman gazları gibi toz yüklü atık gazların ve proses hava ve gazlarının dinamik olarak temizlenmesinde kullanılırlar. Multisiklon filtreler, kirli gaz akımını santrifüj kuvvet kullanarak temizleyen çoklu siklon ünitelerinden oluşur.

Çalışma Prensibi

Kazan veya yakma sisteminden çıkan sıcak gaz, multisiklon filtreye girer.

Gaz, siklon yapısı içerisinde dönerken içindeki partiküller, oluşan santrifüj kuvvetiyle siklon gövdesinin duvarlarına doğru savrulur.

Siklon duvarına çarpan partiküller, siklon konisinin alt kısmına doğru hareket ederek burada toplanır.

Partiküllerden arındırılan gaz, siklon üst çıkışından atık veya baca sistemine iletilir.

Çökelen partiküller, sistemin alt kısmındaki haznede toplanır ve buradan manuel veya otomatik sistemlerle dışarı atılır.

Features

Multicyclones are used for dynamically cleaning dust-laden exhaust gases, such as flue gases, and process air and gases. Multicyclone filters consist of multiple cyclone units that clean the dirty gas flow using centrifugal force.

Working Principle

Hot gases from the boiler or combustion system enter the multicyclone filter.

As the gas spins inside the cyclone structure, the particles within the gas are forced toward the walls of the cyclone body by the centrifugal force.

The particles that hit the cyclone wall move toward the bottom of the cyclone cone, where they are collected.

The gas, now free of particles, exits through the top of the cyclone and is sent to the waste or chimney system.

The settled particles are collected in a chamber at the bottom of the system and are discharged manually or by automatic systems.



| MODEL | TANK BOYUTLARI (TANK SIZES) (mm) (Çap x H top) | BAĞLANTI ÇAPLARI (CONNECTION DIAMETERS) Servis-Drenaj - Tuz Emiş | DEBİ (FLOW) | TUZ TÜKETİMİ (SALT CONSUMPTION) | MİNERALLER (MINERALS) | |
|---------|--|--|----------------------|---------------------------------------|-----------------------|---------|
| | | | | | REÇİNE (RESİN) | QUARTZ |
| | mm | DN | (m ³ / h) | (kg) | (lt) | (kg) |
| S-3072 | 775 x 2050 | 50 - 50 - 25 | 20 | 75 | 500 x 2 | 150 x 2 |
| S-3672 | 975 x 2150 | 65 - 50 - 25 | 27 | 113 | 750 x 2 | 250 x 2 |
| S-4272 | 1075 x 2400 | 65 - 50 - 25 | 32 | 135 | 900 x 2 | 300 x 2 |
| S-4872 | 1225 x 2400 | 80 - 50 - 40 | 42 | 180 | 1200 x 2 | 500 x 2 |
| S-6386 | 1600 x 2500 | 80 - 50 - 40 | 50 | 270 | 1800 x 2 | 800 x 2 |
| ET-1220 | 1250 x 3120 | 80 - 50 - 40 | 50 | 270 | 1800 x 2 | 300 x 2 |
| ET-1620 | 1600 x 3550 | 100 - 80 - 50 | 85 | 420 | 2800 x 2 | 600 x 2 |
| ET-2020 | 2000 x 3550 | 125 - 80 - 50 | 135 | 660 | 4400 x 2 | 500 x 2 |
| ET-2420 | 2400 x 3750 | 150 - 100 - 80 | 180 | 945 | 6300 x 2 | 700 x 2 |

Özellikler

Tandem su yumuşatma sistemleri, endüstriyel ortamlarda sıkça rastlanan yüksek su sertliğini gidermek için tasarlanmıştır. Aquiline marka katyonik reçine ile çalışan sistem, suda bulunan kalsiyum (Ca) ve magnezyum (Mg) iyonlarını tutarak yerine sodyum (Na) iyonu bırakır. Bu iyon değişimi, suyun sertliğini etkin şekilde azaltır.

Standart Boyutlar:

Epoksi boyalı karbon çelik tank, 6 bar maksimum basınç, pnömomatik vanalar (isteğe bağlı aktüatörlü), PVC-U borulama (opsiyonel galvaniz), giriş-çıkışlarda manometre ve numune muslukları, PLC kontrollü panel (opsiyonel dokunmatik ekran), 220 V/50 Hz güç ihtiyacı, 1 L reçineye 150 g tuz, reçine kapasitesi 6000 FR/L.

Operasyon Gereksinimleri:

Pnömomatik vanalar için gerekli kuru hava kullanıcı tarafından sağlanmalıdır. Önerilen hava: 8 bar, 100 L/dk. Sağlam yapısı ve gelişmiş özellikleriyle sistem, uzun ömürlü ve verimli bir çözüm sunar.

Features

Tandem water softening systems are designed to eliminate high water hardness commonly found in industrial settings. Operating with Aquiline cationic resin, the system captures calcium (Ca) and magnesium (Mg) ions and replaces them with sodium (Na) ions through ion exchange, effectively softening the water.

Standard Dimensions:

Epoxy-coated carbon steel tank, 6 bar max pressure, pneumatic valves (optional actuator), PVC-U piping (optional galvanized), manometers and sample taps at inlet/outlet, PLC-based panel (optional touchscreen), power: 220 V/50 Hz, salt: 150 g per liter resin, resin capacity: 6000 FR/L.

Operation Requirements:

Dry compressed air for pneumatic valves must be provided by the user. Recommended air: 8 bar, 100 L/min. With robust design and advanced features, the system offers long-lasting and efficient performance.



| KOD | MODEL | TANK BOYUTLARI (mm) (Çap x Htop) | BAĞLANTI ÇAPLARI (DN-FLANŞ) SERVİS-DRENAJ | SERVİS DEBİSİ (m ³ /saat) | | MİNERALLER | |
|----------|--------|----------------------------------|---|--------------------------------------|----------------|---------------|-------------|
| | | | | Hız = 20m/saat | Hız = 30m/saat | ANTRASİT (lt) | QUARTZ (kg) |
| 50400000 | F-3072 | 775 x 2050 | 50 - 50 | 9 | 14 | 140 | 475 |
| 50400005 | F-3672 | 975 x 2150 | 50 - 50 | 13 | 20 | 175 | 650 |
| 50400010 | F-4272 | 1075 x 2400 | 65 - 65 | 18 | 27 | 210 | 775 |
| 50400015 | F-4872 | 1225 x 2400 | 65 - 65 | 23 | 35 | 315 | 1125 |
| 50400020 | F-6386 | 1600 x 2500 | 80 - 80 | 40 | 60 | 560 | 2025 |

Özellikler

- WCY marka FRP tanklı
- Maksimum çalışma basıncı 6 bar
- Zaman kontrollü ters yıkama
- Elektrik aktüatörlü kelebek vanalar (Pnömatik aktüatörlü olması durumunda fiyat farkı yoktur)
- Alt toplama yapısı ahtapot difüzör
- PVC-U malzeme yüzey borulama (Epoksi boyalı şase üzeri)
- Sistem giriş çıkışlarında numune muslukları ve manometreler
- Elektronik kartlı kontrol panosu
- Elektrik 220V / 50 Hz / 1 pH
- Pnömatik vanaların çalışması için gerekli kuru enstrüman havası temini müşteriye aittir. Önerilen kompresör kapasitesi minimum 100 Lt/dk @ 8 bar'dır.

Features

- WCY brand FRP tank
- Maximum operating pressure: 6 bar
- Time-controlled backwashing
- Electric actuator butterfly valves (No price difference if pneumatic actuator is used)
- Bottom collection system with octopus diffuser
- PVC-U material surface piping (Epoxy painted gas surface)
- Sample taps and pressure gauges at system inlet and outlet
- Electronic card control panel
- Electrical: 220V / 50 Hz / 1 phase
- The supply of dry instrument air required for the operation of pneumatic valves is the responsibility of the customer. The recommended compressor capacity is a minimum of 100 L/min @ 8 bar.



Hava Ekonomizer (Rekuperatör) İmalatı

Air Economizer (Recuperator) Manufacturing



Enerji Santralleri Çelik Kartuş İmalatı

Power Plant Steel Cartridge Manufacturing



Hava Ekonomizer (Rekuperatör) İmalatı

Air Economizer (Recuperator) Manufacturing



Kazan Seviye Kontrol Ekipmanları

Boiler Level Control Equipment



KP-01 Kapasitif
Seviye Transmitteri



NRGS 15-1
Seviye Transmitteri



NRGT 26-2S Oransal
Seviye Kontrol Probu



ELK-4
Seviye Şalteri

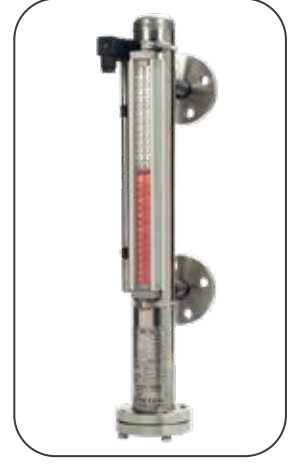

MGK-33 Manyetik
Seviye Göstergesi

Yüzey ve Dip Blöf Sistemleri

Surface and Bottom Blowdown Systems



DBV-10 Dip Blöf
Sistemleri



Dip Blöf
Sistemi



Dip Blöf
Sistemi



Yüzey Blöf
Sistemi



YBS-19 Yüzey Blöf
Sistemi

Kontrol Vanaları

Control Valves



TİP2141-T1
Termostatik Vana



TİP41-23 Basınç
Düşürücü Vana



Emniyet
Ventili



Metal Körüklü
Glob Vana



Elektrik Aktüatörlü
Kelebek Vana

Sayaç ve Vericileri
Counters and Transmitters



Buhar Sayacı



Termokupl



Basınç Şalteri



Basınç Transmitteri



Vakum Cihazı

Pompa ve Hidrofor Grupları
Water Hydrophore Groups



Besi Pompaları



Sert ve Yumuşak Su Hidroforları



Yüksek Basınç Pompaları

I&D Primer Fanlar
FD & ID Fans



Kömür ve Kül Sistemleri

Coal and Ash Systems



Kömür Helezonu
Coal Screw

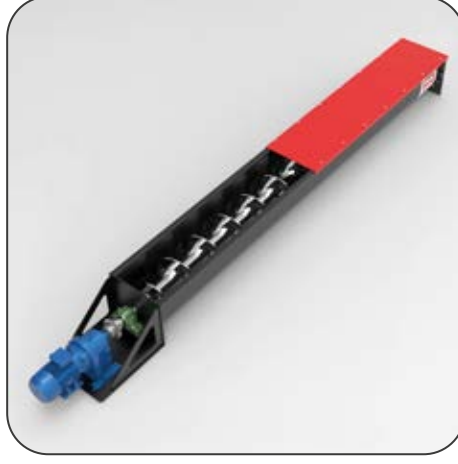

Curuf Helezonu
Slag Screw



Sarsak Elek ve Kırıcı
Sieve and Crusher

Otomasyon ve Pano Sistemleri

Automation and Switchboard Systems







İmalatlarımız

Our Manufacturing







TR Firmamız tarafından enerji santralleri kızdırıcı bakımları ve revizyonları yapılmaktadır.

EN Superheater maintenance and revisions of power plants are carried out by our company.



TR Kızdırıcı Boru İmalatı

Yüksek basınçlı enerji santralleri drum sonrası buhar kızdırıcı demeti imalatları
Kızdırıcı demontaj, montaj ve revizyon işlemleri
Kızdırıcı dirsek kılıf imalatları
Kızdırıcı dirsek değişimleri

EN Superheater Manufacturing

High pressure power plants after the drum steam superheater manufacturing
Superheater disassembly, assembly and revision operations
Superheater pipe bend sheath manufacturing
Superheater pipe bend changes



KİMYA CHEMISTRY



GIDA FOOD

ÇİMENTO CEMENT



ENERJİ ENERGY



KAĞIT PAPER



TR Özgül Entalpi

Z Specific Enthalpy

| Buhar | | Sıcaklık | Su | Buharlaşma | Buhar | Özgül Hacim |
|-------|---------|----------|-------|------------|---------|--------------------|
| bar | kPa | °C | kJ/kg | kJ/kg | kJ/kg | m ³ /kg |
| 2.00 | 200.0 | 133.69 | 562.2 | 2,163.3 | 2,725.5 | 0.603 |
| 2.20 | 220.0 | 135.88 | 571.7 | 2,156.9 | 2,728.6 | 0.568 |
| 2.40 | 240.0 | 138.01 | 580.7 | 2,150.7 | 2,731.4 | 0.536 |
| 2.60 | 260.0 | 140.00 | 589.2 | 2,144.7 | 2,733.9 | 0.509 |
| 2.80 | 280.0 | 141.92 | 597.4 | 2,139.0 | 2,736.4 | 0.483 |
| 3.00 | 300.0 | 143.75 | 605.3 | 2,133.4 | 2,738.7 | 0.461 |
| 3.20 | 320.0 | 145.46 | 612.9 | 2,128.1 | 2,741.0 | 0.440 |
| 3.40 | 340.0 | 147.20 | 620.0 | 2,122.9 | 2,742.9 | 0.422 |
| 3.60 | 360.0 | 148.84 | 627.1 | 2,117.8 | 2,744.9 | 0.405 |
| 3.80 | 380.0 | 150.44 | 634.0 | 2,112.9 | 2,746.9 | 0.389 |
| 4.00 | 400.0 | 151.96 | 640.7 | 2,108.1 | 2,748.8 | 0.374 |
| 4.50 | 450.0 | 155.55 | 656.3 | 2,096.7 | 2,753.0 | 0.342 |
| 5.00 | 500.0 | 158.92 | 670.9 | 2,086.0 | 2,756.9 | 0.315 |
| 5.50 | 550.0 | 162.08 | 684.6 | 2,075.7 | 2,760.3 | 0.292 |
| 6.00 | 600.0 | 165.04 | 697.5 | 2,066.0 | 2,763.5 | 0.272 |
| 6.50 | 650.0 | 167.83 | 709.7 | 2,056.8 | 2,766.5 | 0.255 |
| 7.00 | 700.0 | 170.50 | 721.4 | 2,047.7 | 2,769.1 | 0.240 |
| 7.50 | 750.0 | 173.02 | 732.5 | 2,039.2 | 2,771.7 | 0.227 |
| 8.00 | 800.0 | 175.43 | 743.1 | 2,030.9 | 2,774.0 | 0.215 |
| 8.50 | 850.0 | 77.75 | 753.3 | 2,022.9 | 2,776.2 | 0.204 |
| 9.00 | 900.0 | 179.97 | 763.0 | 2,015.1 | 2,778.1 | 0.194 |
| 9.50 | 950.0 | 182.10 | 772.5 | 2,007.5 | 2,780.0 | 0.185 |
| 10.00 | 1,000.0 | 184.13 | 781.6 | 2,000.1 | 2,781.7 | 0.177 |
| 10,50 | 1,050.0 | 186.05 | 790.1 | 1,993.0 | 2,783.3 | 0.171 |
| 11.00 | 1,100.0 | 188.02 | 798.8 | 1,986.0 | 2,784.8 | 0.163 |
| 11.50 | 1,150.0 | 189.82 | 807.1 | 1,979.1 | 2,786.3 | 0.157 |
| 12.00 | 1,200.0 | 191.68 | 815.1 | 1,972.5 | 2,787.6 | 0.151 |
| 12.50 | 1,250.0 | 193.43 | 822.9 | 1,965.4 | 2,788.8 | 0.148 |
| 13.00 | 1,300.0 | 195.10 | 830.4 | 1,959.6 | 2,790.0 | 0.141 |
| 14.00 | 1,400.0 | 198.35 | 845.1 | 1,947.1 | 2,792.2 | 0.132 |
| 15.00 | 1,500.0 | 201.45 | 859.0 | 1,935.0 | 2,794.0 | 0.124 |
| 16.00 | 1,600.0 | 204.38 | 872.3 | 1,923.4 | 2,795.7 | 0.117 |
| 17.00 | 1,700.0 | 207.17 | 885.0 | 1,912.1 | 2,797.1 | 0.110 |
| 18.00 | 1,800.0 | 209.90 | 897.2 | 1,901.3 | 2,798.5 | 0.105 |
| 19.00 | 1,900.0 | 212.47 | 909.0 | 1,890.5 | 2,799.5 | 0.100 |
| 20.00 | 2,000.0 | 214.96 | 920.3 | 1,880.2 | 2,800.5 | 0.099,4 |
| 21.00 | 2,100.0 | 217.35 | 931.3 | 1,870.1 | 2,801.4 | 0.090,6 |
| 22.00 | 2,200.0 | 219.65 | 941.9 | 1,860.1 | 2,802.0 | 0.086,8 |
| 23.00 | 2,300.0 | 221.85 | 952.2 | 1,850.4 | 2,802.6 | 0.083,2 |
| 24.00 | 2,400.0 | 224.02 | 962.2 | 1,840.9 | 2,803.1 | 0.079,7 |
| 25.00 | 2,500.0 | 226.12 | 972.1 | 1,831.4 | 2,803.5 | 0.076,8 |
| 26.00 | 2,600.0 | 228.15 | 981.6 | 1,822.2 | 2,803.8 | 0.074,0 |
| 27.00 | 2,700.0 | 230.14 | 990.7 | 1,818.3 | 2,804.0 | 0.071,4 |

Buhar Tablosu

Steam Table



TR Buhar Boru Çapı Seçim Tablosu

EN Steam Pipe Diameter Selection Table

| Buhar Basıncı Steam Pressure P(bar) | Buhar Hızı Steam Velocity V(m/s) | Boru Çapı(DN) Tube Diameter(DN) | | | | | | | | | | | | | |
|---|--|---|-----|-----|------|------|------|------|------|------|-------|-------|-------|-------|-------|
| | | 15 | 15 | 25 | 32 | 40 | 50 | 65 | 80 | 100 | 125 | 150 | 200 | 250 | 300 |
| | | SCH40 Siyah Boru Gerçek İç Çapına Göre Hesaplanmış Doymuş Buhar Debisi (kg/h) | | | | | | | | | | | | | |
| | | Steam Flow Rate Calculated According To SCH40 Tube Inside Diameter Given Above (kg/h) | | | | | | | | | | | | | |
| 0.5 | 15 | 9 | 17 | 27 | 48 | 64 | 104 | 175 | 241 | 40 | 623 | 891 | 1535 | 2379 | 3386 |
| | 20 | 13 | 23 | 36 | 63 | 86 | 138 | 233 | 321 | 545 | 831 | 1187 | 2046 | 3172 | 454 |
| | 30 | 19 | 34 | 55 | 95 | 129 | 207 | 349 | 482 | 818 | 1246 | 1781 | 3069 | 4759 | 6772 |
| | 40 | 28 | 46 | 73 | 127 | 172 | 276 | 466 | 642 | 1090 | 1662 | 2375 | 4093 | 6345 | 9029 |
| 1 | 15 | 12 | 22 | 36 | 62 | 84 | 135 | 228 | 315 | 534 | 814 | 1163 | 2005 | 3108 | 4423 |
| | 20 | 16 | 30 | 48 | 83 | 112 | 180 | 304 | 419 | 712 | 1086 | 1551 | 2673 | 4144 | 5897 |
| | 30 | 25 | 45 | 71 | 124 | 168 | 271 | 456 | 629 | 1068 | 1628 | 2327 | 4010 | 6216 | 8845 |
| | 40 | 33 | 60 | 95 | 16 | 224 | 361 | 608 | 839 | 1424 | 2171 | 3102 | 5346 | 8288 | 11794 |
| 2 | 15 | 18 | 33 | 62 | 91 | 123 | 197 | 333 | 459 | 779 | 1188 | 1697 | 2925 | 4535 | 6453 |
| | 20 | 24 | 44 | 69 | 121 | 164 | 263 | 444 | 612 | 1039 | 1584 | 2263 | 3900 | 6047 | 8605 |
| | 30 | 36 | 6 | 104 | 181 | 246 | 395 | 665 | 918 | 1559 | 2376 | 3395 | 5851 | 9070 | 12907 |
| | 40 | 48 | 87 | 139 | 242 | 328 | 527 | 887 | 1224 | 2078 | 3168 | 4527 | 7801 | 12093 | 17209 |
| 3 | 15 | 24 | 43 | 68 | 119 | 161 | 258 | 435 | 601 | 1020 | 1555 | 2222 | 3828 | 5935 | 8446 |
| | 20 | 31 | 57 | 91 | 158 | 214 | 345 | 581 | 801 | 1360 | 2073 | 2962 | 5105 | 7914 | 11261 |
| | 30 | 47 | 86 | 136 | 237 | 321 | 517 | 871 | 1201 | 2040 | 3109 | 4443 | 7657 | 11870 | 16892 |
| | 40 | 63 | 114 | 181 | 316 | 429 | 689 | 1161 | 1602 | 2720 | 4146 | 5924 | 10209 | 15827 | 22523 |
| 4 | 15 | 29 | 53 | 84 | 146 | 198 | 319 | 537 | 740 | 1258 | 1917 | 2739 | 4720 | 7318 | 10413 |
| | 20 | 39 | 71 | 12 | 195 | 264 | 425 | 716 | 987 | 1677 | 2556 | 3652 | 6294 | 9757 | 13884 |
| | 30 | 58 | 106 | 168 | 292 | 396 | 637 | 74 | 1481 | 2515 | 3834 | 5478 | 9440 | 14635 | 20826 |
| | 40 | 77 | 141 | 24 | 390 | 528 | 50 | 1432 | 1975 | 3354 | 5112 | 7304 | 12587 | 19513 | 27768 |
| 5 | 15 | 34 | 63 | 100 | 174 | 235 | 378 | 637 | 879 | 1493 | 2276 | 3252 | 5604 | 8687 | 12362 |
| | 20 | 46 | 84 | 133 | 231 | 314 | 504 | 850 | 1172 | 1991 | 3034 | 4336 | 7472 | 11583 | 16483 |
| | 30 | 69 | 126 | 199 | 347 | 471 | 756 | 1275 | 1758 | 2986 | 4551 | 6504 | 11207 | 17375 | 24725 |
| | 40 | 92 | 168 | 266 | 463 | 627 | 1009 | 1700 | 2344 | 3981 | 6068 | 8671 | 14943 | 23166 | 32966 |
| 6 | 15 | 40 | 73 | 115 | 201 | 272 | 437 | 737 | 1017 | 1727 | 2632 | 3761 | 6481 | 10048 | 14288 |
| | 20 | 53 | 97 | 154 | 268 | 363 | 583 | 983 | 1356 | 2302 | 3509 | 5015 | 8642 | 13397 | 19064 |
| | 30 | 80 | 145 | 230 | 401 | 544 | 875 | 1474 | 2034 | 3454 | 5264 | 7522 | 12963 | 20095 | 28597 |
| | 40 | 106 | 194 | 307 | 535 | 726 | 1167 | 1966 | 2711 | 4605 | 7019 | 10029 | 17283 | 26794 | 38129 |
| 8 | 15 | 51 | 92 | 146 | 255 | 345 | 555 | 935 | 1290 | 2191 | 3340 | 4772 | 8224 | 12750 | 18143 |
| | 20 | 67 | 123 | 195 | 340 | 460 | 740 | 1247 | 1720 | 2922 | 4453 | 6363 | 10966 | 17000 | 24191 |
| | 30 | 101 | 184 | 292 | 509 | 691 | 1110 | 1871 | 2580 | 4382 | 6680 | 9545 | 16448 | 25499 | 36287 |
| | 40 | 135 | 246 | 390 | 679 | 921 | 1480 | 2494 | 3441 | 5843 | 8906 | 12726 | 21931 | 33999 | 48382 |
| 10 | 15 | 61 | 112 | 177 | 308 | 418 | 672 | 1133 | 1562 | 2653 | 4043 | 5778 | 9957 | 15436 | 21966 |
| | 25 | 82 | 149 | 236 | 411 | 557 | 896 | 1510 | 2083 | 3537 | 5391 | 7704 | 13276 | 20581 | 29288 |
| | 30 | 123 | 223 | 354 | 617 | 836 | 1344 | 2265 | 3124 | 5306 | 8087 | 11556 | 19914 | 30872 | 43932 |
| | 40 | 163 | 298 | 472 | 822 | 1115 | 1792 | 3020 | 4165 | 7074 | 10783 | 15408 | 26552 | 41163 | 58576 |
| 12 | 15 | 72 | 131 | 208 | 362 | 491 | 789 | 1329 | 1833 | 3113 | 4745 | 6781 | 11685 | 18115 | 25778 |
| | 25 | 120 | 218 | 346 | 603 | 818 | 1314 | 2215 | 3055 | 5189 | 7909 | 11301 | 19475 | 30191 | 42963 |
| | 40 | 192 | 349 | 554 | 965 | 1308 | 2103 | 3544 | 4888 | 8302 | 12564 | 18081 | 31159 | 48305 | 68741 |
| 14 | 15 | 82 | 150 | 238 | 415 | 563 | 905 | 1525 | 2104 | 3573 | 5446 | 7782 | 13411 | 20791 | 29586 |
| | 25 | 137 | 251 | 397 | 692 | 938 | 1509 | 2542 | 3506 | 5955 | 9077 | 12970 | 22352 | 34651 | 49310 |
| | 40 | 220 | 401 | 636 | 1108 | 1501 | 2414 | 4068 | 5610 | 9529 | 14523 | 20753 | 35763 | 55442 | 78896 |

Hisarmak ile Sınırların Ötesinde

Beyond Borders with Hisarmak

*"Bugün 4 kıtada yüzlerce müşteriye hizmet veriyor,
endüstriyel kazan ve ekipmanlarımızla
güvenilir çözümler sunuyoruz."*

*"Today, we serve hundreds of clients across 4 continents,
delivering reliable solutions with our
industrial boilers and equipment."*

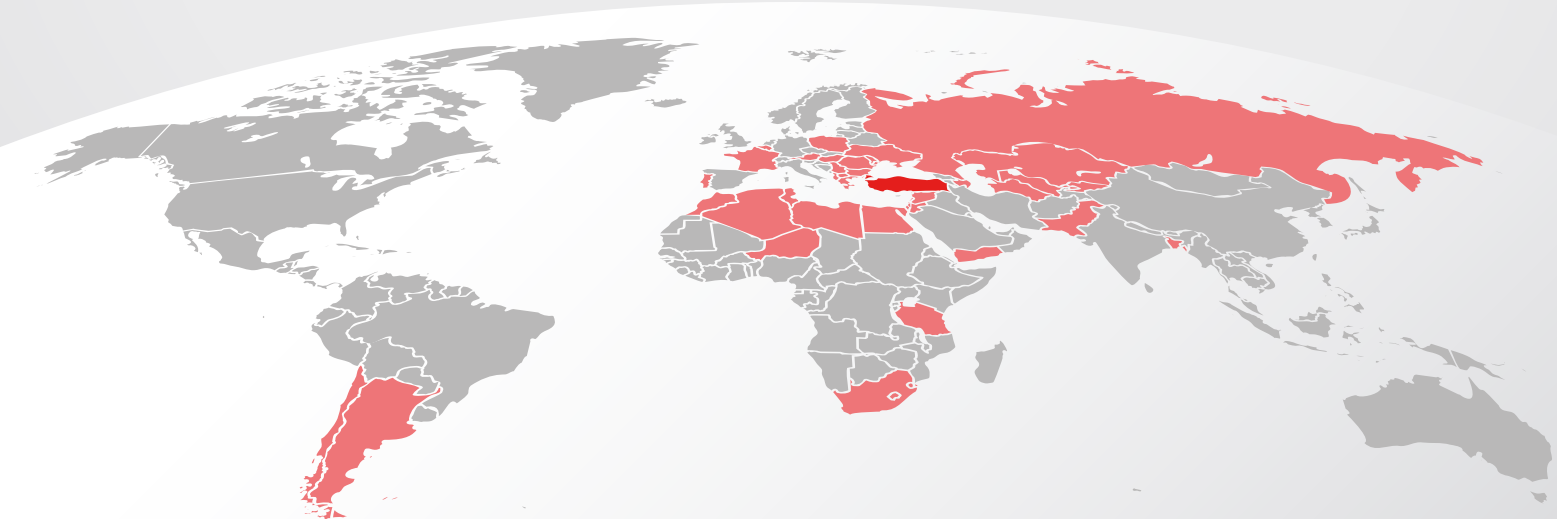



Confidence and Quality

Bize Ulařın Contact Us



www.hisarmak.com.tr



satis@hisarmak.com.tr
sales@hisarmak.com.tr



Hisarmak Endüstriyel Kazan Sistemleri
Hisarmak Industrial Boiler Systems

Fabrika Factory



+90 344 237 66 66



+90 533 141 69 46



Hacı Mustafa Mah.
Gazi Mustafa Kemal Blv. No:140/A
Onikişubat / KAHRAMANMARAŞ

Ofis Office



+90 282 502 36 46



VIAWEST-5 Hatip Mah.
Akasma Sk. No H-1 [4CG]
Çorlu / TEKİRDAĞ